



APPROVALS



ENGINEERING CODE
194PA67

APPROVED REFRIGERANT
R-134a

POWER SUPPLY
220-240 V 50 Hz

STANDARD CONDITIONS
ASHRAE

APPLICATION
HBP

COOLING CAPACITY
580 W (HBP)

EFFICIENCY
2.61 W/W (HBP)

MOTOR TYPE
CSIR

STARTING TORQUE
HST

DATA

General Data

Type	Hermetic reciprocating
Technology Type	On-Off
Displacement	5.19 cm ³
Compressor Cooling	Fan/NotControlled/220
Expansion Device	Capillary Tube or Expansion Valve
Horse Power	1/5 hp
Power Supply	220-240 V 50 Hz
Evaporating Temperature Range	-15 °C to 10 °C

Electrical Data

Motor type	CSIR
Starting Torque	HST

Mechanical Data

Oil Charge	180 ml
Oil Type Configuration	ESTER
Oil Type Viscosity	ISO22
Weight	7.8 Kg

Electrical Components

	Description
Start Capacitor	43-53 Uf / 330 V
Starting Device	Relay MTRP-34*
Motor Protection	T0827/G6

External Characteristics

Tray Holder	Yes	
Connector	Internal Diameter	Shape
Suction	6.1 mm	Slanted 42°/Copper
Discharge	4.86 mm	Straight/Copper
Process	6.1 mm	Slanted 42°/Copper

PERFORMANCE

Rated Points

Condensing Temperature	Evaporating Temperature	Cooling Capacity	Power Consumption	Current	Gas Flow Rate	Efficiency
54.40°C	7.20°C	580 W	222 W	1.38 A	12.84 kg/h	2.61 W/W

Test Condition: ASHRAEHBP46, Fan/NotControlled/220, Return Gas 35°C, Evaporation 7.20°C, Condensing 54.40°C, Ambient 35°C, Liquid 46.1°C, Subcooling 8.3K. Data in accordance to EN

12900:2013 and AHRI 540:2015 polynomial equation and uncertainty guidance.

Performance Curve Data

Condensing Temperature 35°C

Evaporating Temperature °C	Cooling Capacity W	Power W	Current A	Gas Flow Rate kg/h	Efficiency W/W
-15	338	131	1.08	6.23	2.57
-10	426	142	1.11	7.88	2.99
-5	530	154	1.14	9.86	3.45
0	652	165	1.17	12.17	3.95
5	789	176	1.21	14.80	4.49
10	940	185	1.24	17.75	5.07

Test Condition: ASHRAEHBP46, Fan/NotControlled/220, Return Gas 35°C, Ambient 35°C, Subcooling 8.3K. Data in accordance to EN 12900:2013 and AHRI 540:2015 polynomial equation and

uncertainty guidance.

Condensing Temperature 45°C

Evaporating Temperature °C	Cooling Capacity W	Power W	Current A	Gas Flow Rate kg/h	Efficiency W/W
-15	276	139	1.1	5.51	1.99
-10	348	152	1.14	6.96	2.28
-5	436	167	1.18	8.75	2.61
0	539	182	1.22	10.88	2.97
5	657	196	1.27	13.34	3.35
10	789	210	1.31	16.13	3.76

Test Condition: ASHRAEHBP46, Fan/NotControlled/220, Return Gas 35°C, Ambient 35°C, Subcooling 8.3K. Data in accordance to EN 12900:2013 and AHRI 540:2015 polynomial equation and uncertainty guidance.

Condensing Temperature 55°C

Evaporating Temperature °C	Cooling Capacity W	Power W	Current A	Gas Flow Rate kg/h	Efficiency W/W
-15	220	149	1.12	4.79	1.48
-10	274	164	1.18	5.98	1.67
-5	343	181	1.24	7.52	1.9
0	427	198	1.3	9.41	2.16
5	525	215	1.36	11.65	2.45
10	637	232	1.43	14.22	2.75

Test Condition: ASHRAEHBP46, Fan/NotControlled/220, Return Gas 35°C, Ambient 35°C, Subcooling 8.3K. Data in accordance to EN 12900:2013 and AHRI 540:2015 polynomial equation and uncertainty guidance.

Operating Envelope

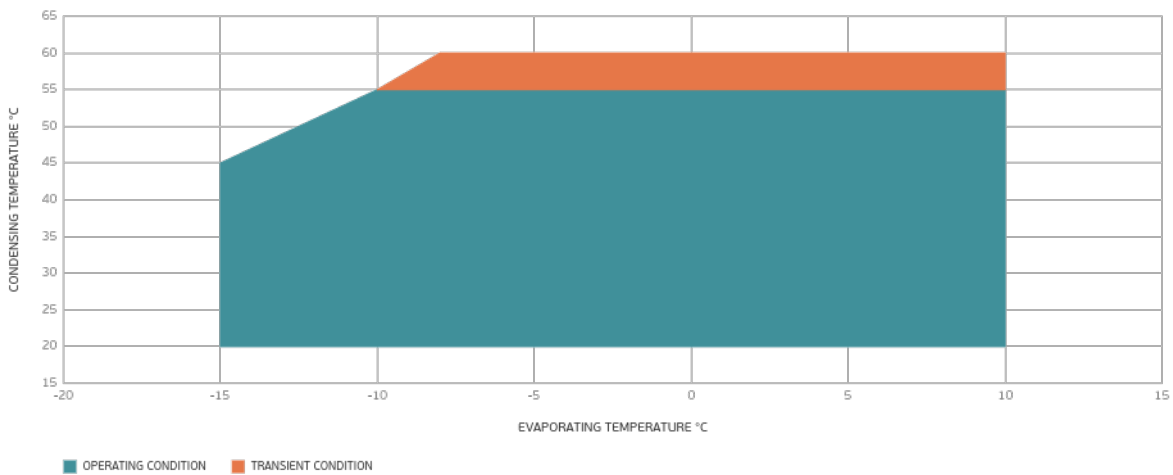

External Dimensions

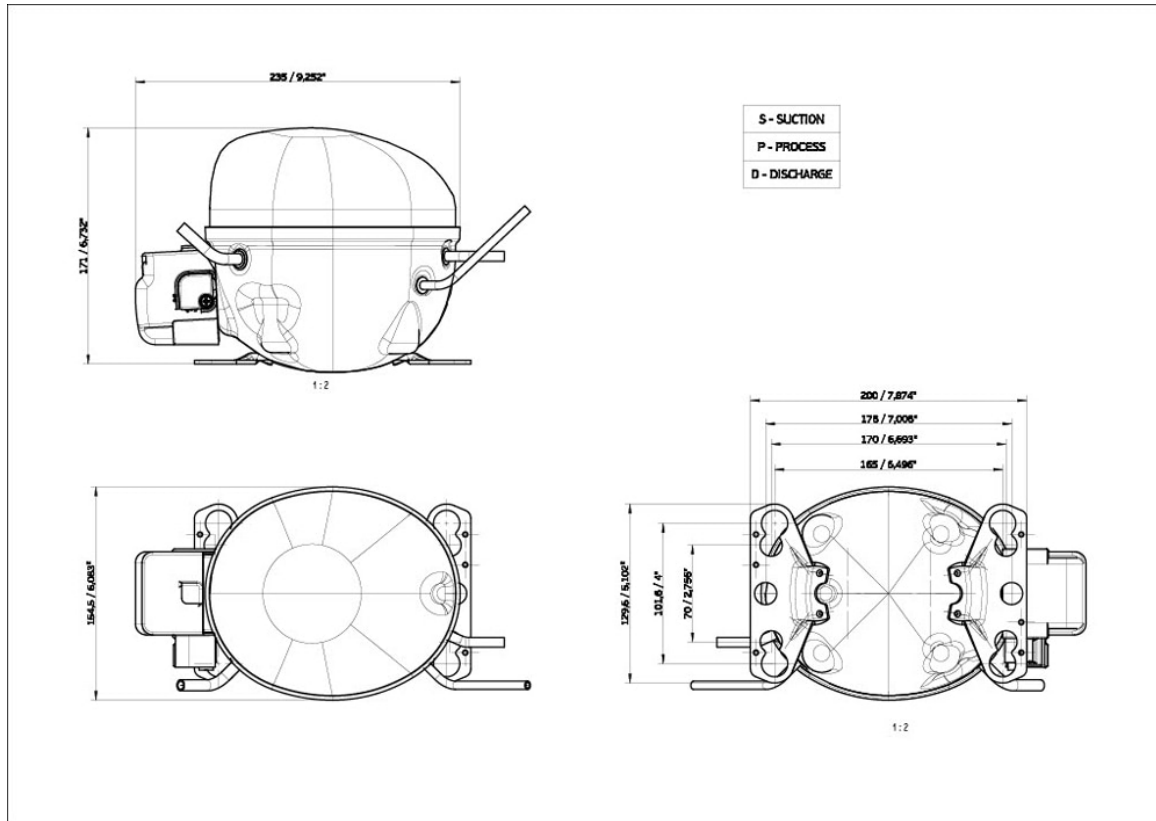

Wiring Diagram

SM28-4

