



Новый модельный ряд АЕ²

Current AE



New AE²

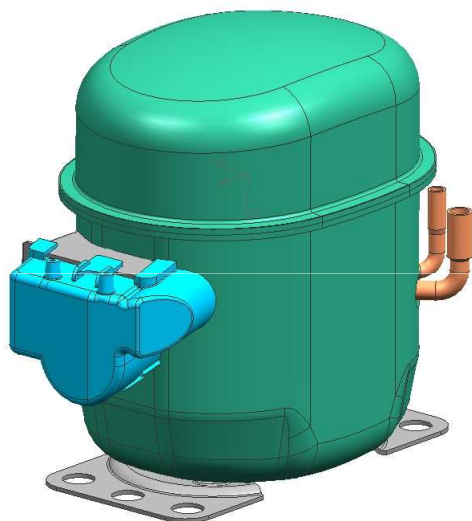

2011 – Производства в Бразилии
2012 – Производство во Франции

- ✓ Лучшая эффективность
- ✓ R290, R600a, R134a, R404A
- ✓ Препрежние межосевые расстояния
- ✓ Меньшие размеры
- ✓ Удобный доступ к электрокомпонентам
- ✓ Удобное расположение патрубков
- ✓ Оптимизированное использование масла
- ✓ Меньшие вибрации
- ✓ Расширение модельного ряда

Full Product Optimization
All Compressor functions revisited
Re-engineer compressor

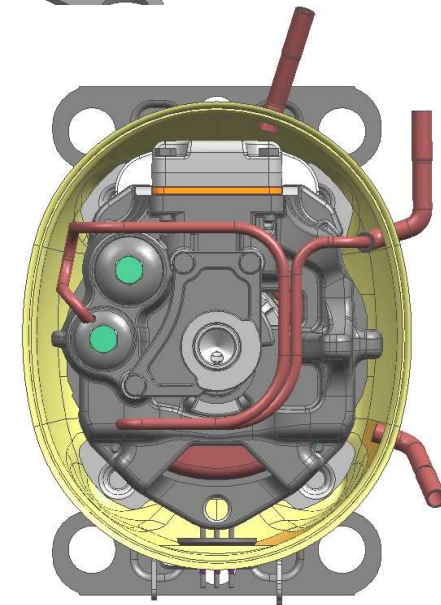
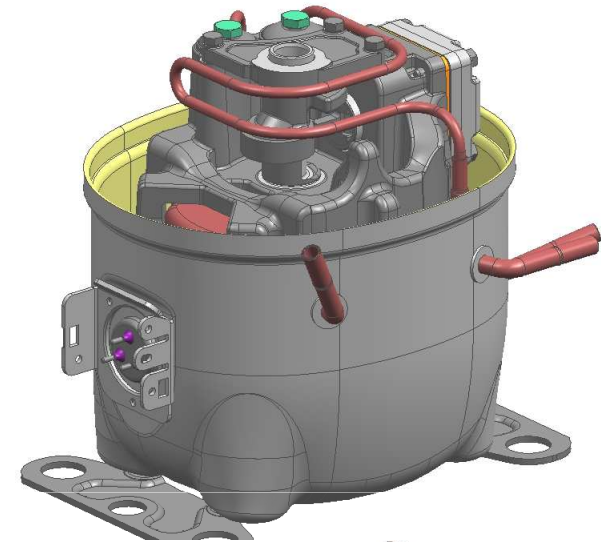
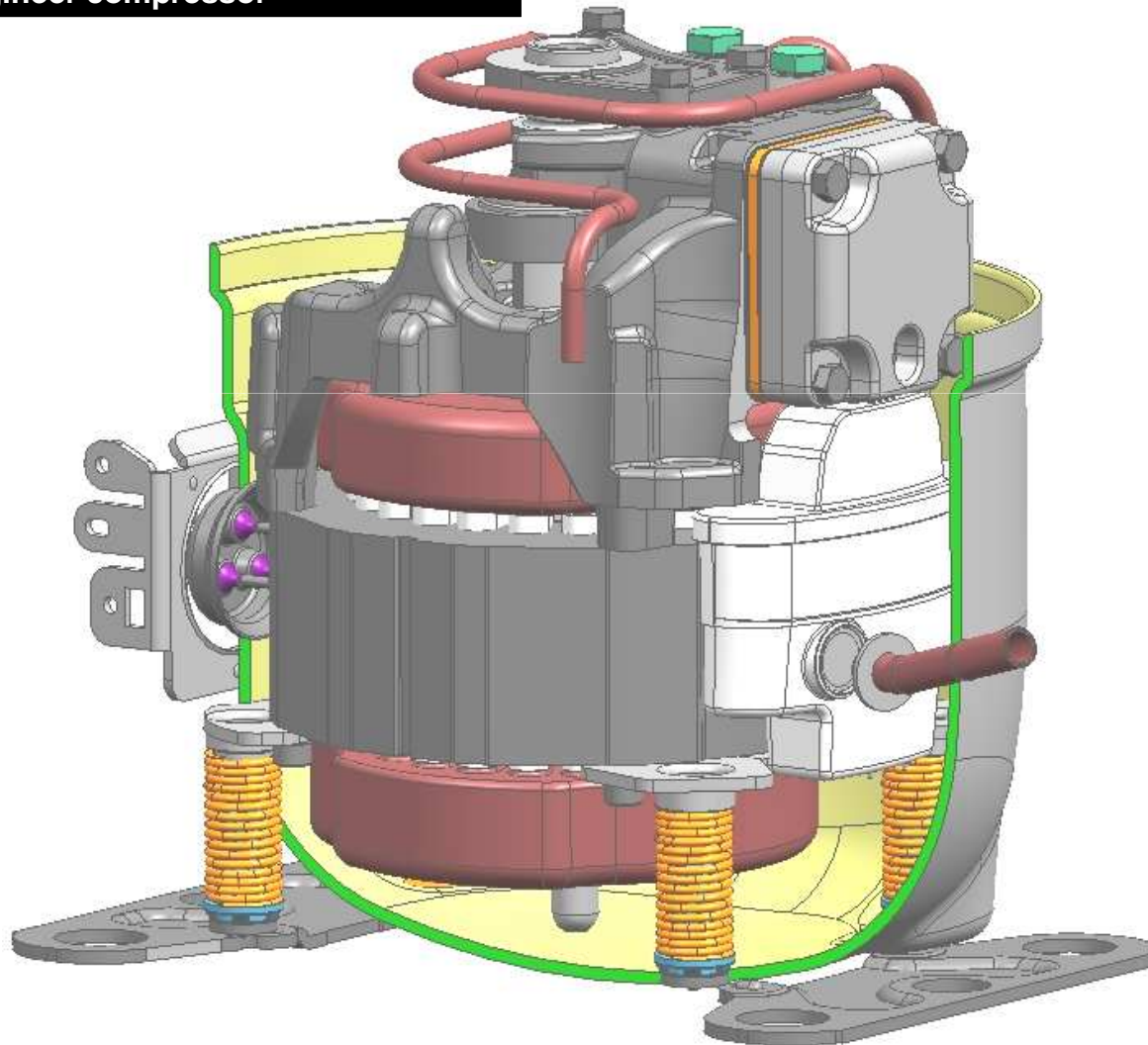

Current AE

New AE²

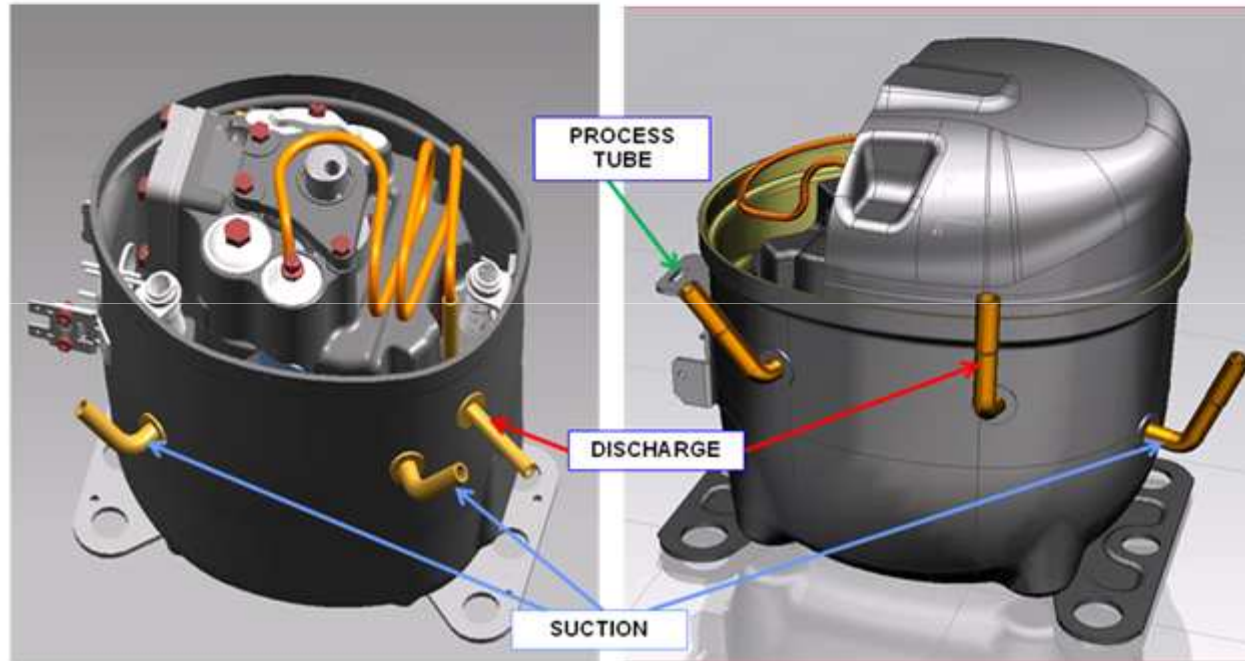

Модель:

Индекс модификации
А В С итд

AE4440U-XX3Z

Типоразмер

X, Y and/or Z =
Специальное исполнение

- 0 9- CBP (reutilize in the future)
- 1 2- LBP
- 3 4- HBP
- 5 – AC
- L – AC (Super-tropical)
- M - AC (Tropical)
- N – LBP (Super-Tropical)
- P – LBP (Tropical)
- R – HBP (Super-Tropical)
- S – HBP (Tropical)
- 8 -

Область применения
LBP/HBP

Номинальная холодопроизвод.
в Вт/ч при 60Гц

Код напряжения

Рабочий конденсатор

Хладагент

- 1 Без рабочего конденсатора
- 2 Возможность использования рабочего конденсатора
- 3 С рабочим конденсатором
- 4 Для AC с пусковым и рабочим конденсаторами



Модельный ряд



R290		R134a		R404A		R600a
HBP	LBP	HBP	LBP	HBP	LBP	LBP
AE 3425U	AE 1415U	AE 3425Y	AE 1390Y	AE 3425Z	AE 1410Z	-
AE 4425U	AE 2415U	AE 4425Y	AE 2390Y	AE 4425Z	AE 2410Z	-
AE 3430U	AE 1420U	AE 3430Y	AE 1410Y	AE 3430Z	AE 1415Z	-
AE 4430U	AE 2420U	AE 4430Y	AE 2410Y	AE 4430Z	AE 2415Z	-
AE 3440U	AE 1425U	AE 3440Y	AE 1413Y	AE 3440Z	AE 1420Z	AE 1380M
AE 4440U	AE 2425U	AE 4440Y	AE 2413Y	AE 4440Z	AE 2420Z	AE 2380M
AE 3450U		AE 4450Y	AE 1415Y	AE 3450Z	AE 2425Z	AE 1390M
AE 4450U		AE 4456Y	AE 2415Y	AE 4450Z		AE 2390M
AE 4460U				AE 4460Z		
				AE 4470Z		

Note: R600a available in 2012



Таблица аналогов к текущему модельному ряду АЕ АЕ



Current compressor	new AE	Current compressor	new AE
HBP 134a		HBP 404A	
AEZ3425Y	AE 3425Y	AEZ3425Z	AE 3425Z
AEZ4425Y	AE 4425Y	AEZ4425Z	AE 4425Z
AEZ3430Y	AE 3430Y	AEZ3430Z	AE 3430Z
AEZ4430Y	AE 4430Y	AEZ4430Z	AE 4430Z
AE3440Y	AE 3440Y	AEZ3440Z	AE 3440Z
CAE4440Y	AE 4440Y	AEZ4440Z	AE 4440Z
CAE4450Y	AE 4450Y	AE3450Z	AE 3450Z
CAE4456Y	AE 4460Y	CAE4450Z/CAI	AE 4450Z
		CAE4460Z/CAI	AE 4460Z
		CAE9470Z	AE 4470Z
LBP 134a		LBP R404A	
AEZ1380Y	AE 1390Y	AEZ1411Z	AE 1410Z
AEZ2380Y	AE 2390Y	AEZ2411Z	AE 2410Z
AE1410Y	AE 1410Y	AEZ1415Z	AE 1415Z
CAE2410Y	AE 2410Y	AEZ2415Z/CAE	AE 2415Z
AE1412Y	AE 1413Y	AE1420Z	AE 1420Z
CAE2412Y	AE 2413Y	CAE2420Z	AE 2420Z
	AE 1415Y	CAE2424Z	AE 2425Z
CAE2414Y	AE 2415Y		



Технические характеристики



R290 (Propane)					Test Conditions												
Oil Type: POE 22, Oil Volume: 280 ml					ASHRAE 46												
					CBP Evaporating Temp. 20°F (-6.7°C)						HBP Evaporating Temp. 45°F (7.2°C)						
					Cooling Capacity			Efficiency (EER)			COP			Cooling Capacity			Efficiency (EER)
Model Number	Motor Type	Voltage Range	Freq. Hz	Displacement CM ³	Btu/h	kcal/h	W	Btu/Wh	kcal/Wh	W/W	Btu/h	kcal/h	W	Btu/Wh	kcal/Wh	W/W	
AE4440U-AA1A	CSIR	115	60	8.02	2700	680	791	6.45	1.62	1.89	4520	1138	1324	9.26	2.33	2.71	
AE4440U-AA3A	CSR	115	60	8.02	2700	680	791	6.97	1.75	2.04	4520	1138	1324	10.00	2.52	2.93	
AE4460U-AA1C	CSIR	115	60	12.07	4170	1050	1222	6.40	1.61	1.87	6830	1719	2001	8.81	2.22	2.58	
AE4460U-AA3C	CSR	115	60	12.07	4170	1050	1222	6.91	1.74	2.02	6830	1719	2001	9.51	2.39	2.79	
AE4460U-FZ1C	CSIR	220-240	50	12.07	3410	858	999	6.39	1.61	1.87	5580	1404	1635	8.86	2.23	2.59	
AE4460U-FZ3C	CSR	220-240	50	12.07	3410	858	999	6.90	1.74	2.02	5580	1404	1635	9.57	2.41	2.80	
AE4425U-FZ1A*	CSIR	220-240	50	5.02	1350	340	396	6.20	1.56	1.82	2250	566	659	8.90	2.24	2.61	
AE4425U-FZ3A*	CSR	220-240	50	5.02	1350	340	396	6.70	1.68	1.96	2250	566	659	9.61	2.42	2.81	
AE4440U-FZ1A	CSIR	220-240	50	8.02	2150	541	630	6.13	1.54	1.80	3610	909	1058	8.85	2.23	2.59	
AE4440U-FZ3A	CSR	220-240	50	8.02	2150	541	630	6.62	1.67	1.94	3610	909	1058	9.56	2.40	2.80	
R134a																	
Oil Type: POE 22, Oil Volume: 280 ml																	
AE4430Y-AA1A	CSIR	115	60	8.02	1870	471	548	5.70	1.43	1.67	3400	856	996	8.23	2.07	2.41	
AE4430Y-AA3A	CSR	115	60	8.02	1870	471	548	6.10	1.53	1.79	3400	856	996	8.81	2.21	2.58	
AE4440Y-AA1A	CSIR	115	60	10.38	2430	612	712	5.86	1.47	1.72	4360	1097	1277	8.00	2.01	2.34	
AE4440Y-AA3A	CSR	115	60	10.38	2430	612	712	6.27	1.58	1.84	4360	1097	1277	8.56	2.15	2.51	
AE3425Y-AA1A	RSIR	115	60	6.69	1500	378	440	5.79	1.46	1.70	2800	705	820	8.30	2.09	2.43	
AE3425Y-AA3A	RSIR	115	60	6.69	1500	378	440	6.20	1.56	1.81	2800	705	820	8.88	2.23	2.60	
AE4430Y-FZ1A	CSIR	220-240	50	8.02	1570	395	460	6.30	1.58	1.84	2800	705	820	8.40	2.11	2.46	
AE4430Y-FZ3A	CSR	220-240	50	8.02	1570	395	460	6.74	1.70	1.97	2800	705	820	8.99	2.26	2.63	
AE4440Y-FZ1A	CSIR	220-240	50	10.38	2050	516	601	5.76	1.45	1.69	3650	919	1069	8.15	2.05	2.39	
AE4440Y-FZ3A	CSR	220-240	50	10.38	2050	516	601	6.16	1.55	1.80	3650	919	1069	8.72	2.19	2.55	
AE4440Y-FS1A*	CSIR	220	50	10.38	2050	516	601	5.51	1.39	1.61	3650	919	1069	7.80	1.96	2.28	
AE4440Y-FS1A*	CSR	220	50	10.38	2050	516	601	5.90	1.48	1.73	3650	919	1069	8.35	2.10	2.44	

* Model under development

R404A models under development



Технические характеристики



R290 (Propane)										
Oil Type: POE 22, Oil Volume: 280 ml					Test Conditions					
					ASHRAE 32					
					LBP Evap. Temp. -10°F (-23.3°C)					
Model Number	Motor Type	Voltage Range	Freq. Hz	Displacement CM³	Cooling Capacity			Efficiency (EER)		COP
					Btu/h	kcal/h	W	Btu/Wh	kcal/Wh	W/W
AE2420U-FZ1B	CSIR	220-240	50	11.02	1730	435.10	505.16	4.7	1.18	1.38
AE2415U-FZ1A*	CSIR	220-240	50	8.85	1350	339.53	394.20	4.9	1.23	1.43
AE2415U-FZ3A*	SCR	220-240	50	8.85	1350	339.53	394.20	5.194	1.31	1.52

* Model under development

R404A models under development



Таблица аналогов



Capacity*	AE ²	Embraco	Danfoss	Cubigel
HBP134a	AE 3425Y			
700W	AE 4425Y	NEK6160Z	NL7,3MF	
800W	AE 3430Y			
	AE 4430Y	NEK6170Z EMT 6170Z	NL8,4MF	GLY80RAb
	AE 3440Y			
1000W	AE 4440Y	NEK6187Z	NL11MF	GPY12RAb
	AE 4450Y	NEK6210Z		
	AE 4460Y	NEK6212Z	SC15GH	GPY14RAb
1500W		NEK6214Z		

Capacity*	AE ²	Embraco	Danfoss
LBP134a			
250W	AE 1390Y		
	AE 2390Y	NEK2121Z	NL10FT
	AE 1410Y		
	AE 2410Y	NEK3130Z	SC15FT
350W	AE 1413Y		
	AE 2413Y	NE2134Z	
	AE 1415Y		
	AE 2415Y	NEK2140Z	
450W			

Таблица аналогов

Capacity*	AE ²	Embraco	Danfoss
HBP404A			
700W	AE 3425Z AE 4425Z AE 3430Z	NEK6144GK	
1000W	AE 4430Z AE 3440Z AE 4440Z	NEK6165GK	
1300W	AE 3450Z AE 4450Z	NEK6181GK	NL7MLX
1700W	AE 4460Z	NEK6210GK	
200W	AE 4470Z	NEK6213GK NEK6217GK	

Capacity*	AE ²	Embraco	Danfoss
LBP404A			
250W	AE 1410Z AE 2410Z AE 1415Z		NL7CLX
400W	AE 2415Z AE 1420Z	NEK2125GK NEK2130GK	SC10CLX
700W	AE 2420Z AE 2425Z	NEK2134GK NEK2168GK	



Таблица аналогов



Capacity*	AE ²	Embraco	Danfoss
HBP R290			
600W	AE 3425U AE 4425U AE 3430U AE 4430U	NEK6152U	
800W	AE 3440U AE 4440U	NEK6165U	
900W	AE 3450U AE 4450U AE 4460U	NEK6181U NEK6210U	
1200W			

Capacity*	AE ²	Embraco	Danfoss
LBP R290		NEK2117U	
200W	AE 1415U AE 2415U AE 1420U	NEK2125U	SC10CNX
450W	AE 2420U AE 1425U	NEK2134U	SC12CNX
600W	AE 2425U	NEK2150U	SC12CNX
700W			

*EN12900